

Aリーグ予選結果

【Aリーグ男子予選】 8日（木）とうべつ学園

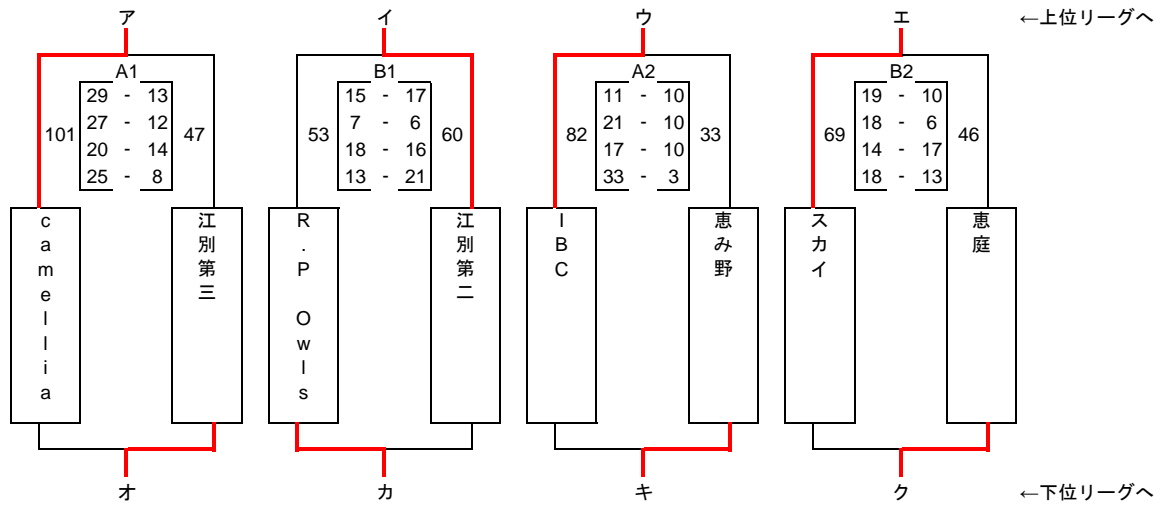

【Aリーグ女子予選】 7日（水）とうべつ学園

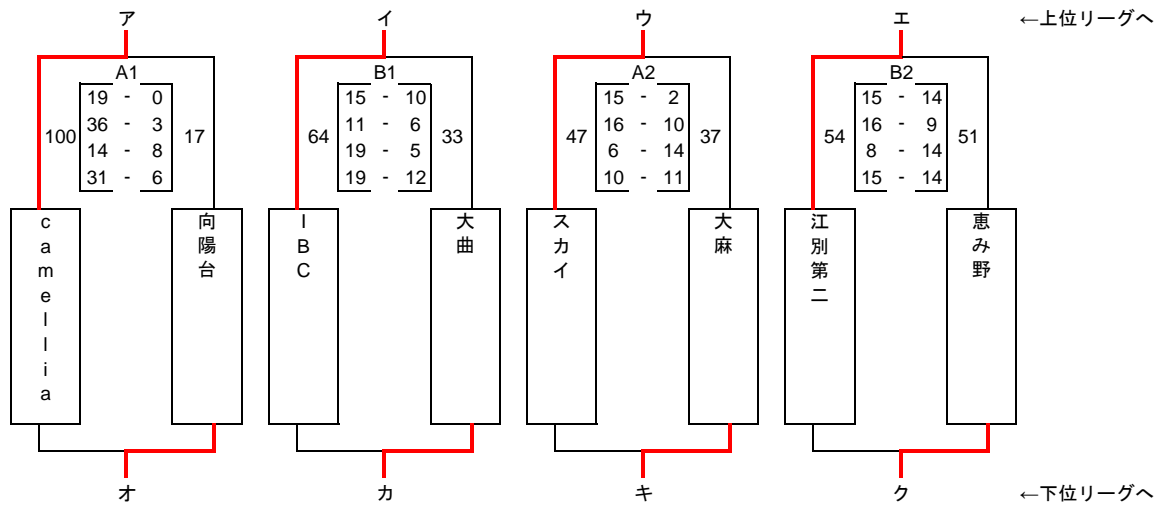

Aリーグ男子 上位リーグ結果

	camellia	江別第二	IBC	スカイ	勝	負	順位												
camellia	/	93 <table style="display: inline-table; border: 1px solid black; padding: 2px;"> <tr><td>22 - 21</td></tr> <tr><td>23 - 20</td></tr> <tr><td>23 - 17</td></tr> <tr><td>25 - 14</td></tr> </table> 72 <table style="display: inline-table; border: 1px solid black; padding: 2px;"> <tr><td>21 - 11</td></tr> <tr><td>19 - 9</td></tr> <tr><td>8 - 13</td></tr> <tr><td>28 - 17</td></tr> </table> 50 <table style="display: inline-table; border: 1px solid black; padding: 2px;"> <tr><td>22 - 14</td></tr> <tr><td>20 - 16</td></tr> <tr><td>18 - 11</td></tr> <tr><td>13 - 13</td></tr> </table> 54	22 - 21	23 - 20	23 - 17	25 - 14	21 - 11	19 - 9	8 - 13	28 - 17	22 - 14	20 - 16	18 - 11	13 - 13	3		1		
22 - 21																			
23 - 20																			
23 - 17																			
25 - 14																			
21 - 11																			
19 - 9																			
8 - 13																			
28 - 17																			
22 - 14																			
20 - 16																			
18 - 11																			
13 - 13																			
江別第二	72 <table style="display: inline-table; border: 1px solid black; padding: 2px;"> <tr><td>21 - 22</td></tr> <tr><td>20 - 23</td></tr> <tr><td>17 - 23</td></tr> <tr><td>14 - 25</td></tr> </table> 93	21 - 22	20 - 23	17 - 23	14 - 25	/	60 <table style="display: inline-table; border: 1px solid black; padding: 2px;"> <tr><td>12 - 25</td></tr> <tr><td>21 - 16</td></tr> <tr><td>13 - 18</td></tr> <tr><td>14 - 16</td></tr> </table> 75 <table style="display: inline-table; border: 1px solid black; padding: 2px;"> <tr><td>11 - 11</td></tr> <tr><td>11 - 13</td></tr> <tr><td>24 - 18</td></tr> <tr><td>20 - 7</td></tr> </table> 49	12 - 25	21 - 16	13 - 18	14 - 16	11 - 11	11 - 13	24 - 18	20 - 7	1	2	3	
21 - 22																			
20 - 23																			
17 - 23																			
14 - 25																			
12 - 25																			
21 - 16																			
13 - 18																			
14 - 16																			
11 - 11																			
11 - 13																			
24 - 18																			
20 - 7																			
IBC	50 <table style="display: inline-table; border: 1px solid black; padding: 2px;"> <tr><td>11 - 21</td></tr> <tr><td>9 - 19</td></tr> <tr><td>13 - 8</td></tr> <tr><td>17 - 28</td></tr> </table> 76 <table style="display: inline-table; border: 1px solid black; padding: 2px;"> <tr><td>25 - 12</td></tr> <tr><td>16 - 21</td></tr> <tr><td>18 - 13</td></tr> <tr><td>16 - 14</td></tr> </table> 60	11 - 21	9 - 19	13 - 8	17 - 28	25 - 12	16 - 21	18 - 13	16 - 14	75 <table style="display: inline-table; border: 1px solid black; padding: 2px;"> <tr><td>4 - 22</td></tr> <tr><td>13 - 24</td></tr> <tr><td>10 - 10</td></tr> <tr><td>12 - 8</td></tr> </table> 64	4 - 22	13 - 24	10 - 10	12 - 8	64	39	2	1	2
11 - 21																			
9 - 19																			
13 - 8																			
17 - 28																			
25 - 12																			
16 - 21																			
18 - 13																			
16 - 14																			
4 - 22																			
13 - 24																			
10 - 10																			
12 - 8																			
スカイ	54 <table style="display: inline-table; border: 1px solid black; padding: 2px;"> <tr><td>14 - 22</td></tr> <tr><td>16 - 20</td></tr> <tr><td>11 - 18</td></tr> <tr><td>13 - 13</td></tr> </table> 73 <table style="display: inline-table; border: 1px solid black; padding: 2px;"> <tr><td>11 - 11</td></tr> <tr><td>13 - 11</td></tr> <tr><td>18 - 24</td></tr> <tr><td>7 - 20</td></tr> </table> 49 <table style="display: inline-table; border: 1px solid black; padding: 2px;"> <tr><td>4 - 22</td></tr> <tr><td>13 - 24</td></tr> <tr><td>10 - 10</td></tr> <tr><td>12 - 8</td></tr> </table> 39	14 - 22	16 - 20	11 - 18	13 - 13	11 - 11	13 - 11	18 - 24	7 - 20	4 - 22	13 - 24	10 - 10	12 - 8	/			3	4	
14 - 22																			
16 - 20																			
11 - 18																			
13 - 13																			
11 - 11																			
13 - 11																			
18 - 24																			
7 - 20																			
4 - 22																			
13 - 24																			
10 - 10																			
12 - 8																			

Aリーグ男子 下位リーグ結果

	江別第三	R.P Owls	恵み野	恵庭	勝	負	順位													
江別第三	/	41 <table style="display: inline-table; border: 1px solid black; padding: 2px;"> <tr><td>7 - 20</td></tr> <tr><td>14 - 18</td></tr> <tr><td>8 - 21</td></tr> <tr><td>12 - 18</td></tr> </table> 77 <table style="display: inline-table; border: 1px solid black; padding: 2px;"> <tr><td>15 - 11</td></tr> <tr><td>6 - 9</td></tr> <tr><td>17 - 17</td></tr> <tr><td>9 - 11</td></tr> </table> 48 <table style="display: inline-table; border: 1px solid black; padding: 2px;"> <tr><td>10 - 12</td></tr> <tr><td>9 - 15</td></tr> <tr><td>6 - 18</td></tr> <tr><td>12 - 9</td></tr> </table> 54	7 - 20	14 - 18	8 - 21	12 - 18	15 - 11	6 - 9	17 - 17	9 - 11	10 - 12	9 - 15	6 - 18	12 - 9	3		4			
7 - 20																				
14 - 18																				
8 - 21																				
12 - 18																				
15 - 11																				
6 - 9																				
17 - 17																				
9 - 11																				
10 - 12																				
9 - 15																				
6 - 18																				
12 - 9																				
R.P Owls	77 <table style="display: inline-table; border: 1px solid black; padding: 2px;"> <tr><td>20 - 7</td></tr> <tr><td>18 - 14</td></tr> <tr><td>21 - 8</td></tr> <tr><td>18 - 12</td></tr> </table> 41	20 - 7	18 - 14	21 - 8	18 - 12	/	57 <table style="display: inline-table; border: 1px solid black; padding: 2px;"> <tr><td>26 - 11</td></tr> <tr><td>15 - 14</td></tr> <tr><td>6 - 21</td></tr> <tr><td>10 - 16</td></tr> </table> 62 <table style="display: inline-table; border: 1px solid black; padding: 2px;"> <tr><td>14 - 10</td></tr> <tr><td>23 - 22</td></tr> <tr><td>20 - 11</td></tr> <tr><td>13 - 17</td></tr> </table> 60	26 - 11	15 - 14	6 - 21	10 - 16	14 - 10	23 - 22	20 - 11	13 - 17	2	1	2		
20 - 7																				
18 - 14																				
21 - 8																				
18 - 12																				
26 - 11																				
15 - 14																				
6 - 21																				
10 - 16																				
14 - 10																				
23 - 22																				
20 - 11																				
13 - 17																				
恵み野	48 <table style="display: inline-table; border: 1px solid black; padding: 2px;"> <tr><td>11 - 15</td></tr> <tr><td>9 - 6</td></tr> <tr><td>17 - 17</td></tr> <tr><td>11 - 9</td></tr> </table> 47 <table style="display: inline-table; border: 1px solid black; padding: 2px;"> <tr><td>11 - 26</td></tr> <tr><td>14 - 15</td></tr> <tr><td>21 - 6</td></tr> <tr><td>16 - 10</td></tr> </table> 57	11 - 15	9 - 6	17 - 17	11 - 9	11 - 26	14 - 15	21 - 6	16 - 10	62 <table style="display: inline-table; border: 1px solid black; padding: 2px;"> <tr><td>13 - 17</td></tr> <tr><td>18 - 14</td></tr> <tr><td>10 - 13</td></tr> <tr><td>10 - 7</td></tr> <tr><td>6 - 3</td></tr> </table> 54	13 - 17	18 - 14	10 - 13	10 - 7	6 - 3	57	54	3		1
11 - 15																				
9 - 6																				
17 - 17																				
11 - 9																				
11 - 26																				
14 - 15																				
21 - 6																				
16 - 10																				
13 - 17																				
18 - 14																				
10 - 13																				
10 - 7																				
6 - 3																				
恵庭	54 <table style="display: inline-table; border: 1px solid black; padding: 2px;"> <tr><td>12 - 10</td></tr> <tr><td>15 - 9</td></tr> <tr><td>18 - 6</td></tr> <tr><td>9 - 12</td></tr> </table> 37 <table style="display: inline-table; border: 1px solid black; padding: 2px;"> <tr><td>10 - 14</td></tr> <tr><td>22 - 23</td></tr> <tr><td>11 - 20</td></tr> <tr><td>17 - 13</td></tr> </table> 60 <table style="display: inline-table; border: 1px solid black; padding: 2px;"> <tr><td>17 - 13</td></tr> <tr><td>14 - 18</td></tr> <tr><td>13 - 10</td></tr> <tr><td>7 - 10</td></tr> <tr><td>3 - 6</td></tr> </table> 57	12 - 10	15 - 9	18 - 6	9 - 12	10 - 14	22 - 23	11 - 20	17 - 13	17 - 13	14 - 18	13 - 10	7 - 10	3 - 6	/			1	2	3
12 - 10																				
15 - 9																				
18 - 6																				
9 - 12																				
10 - 14																				
22 - 23																				
11 - 20																				
17 - 13																				
17 - 13																				
14 - 18																				
13 - 10																				
7 - 10																				
3 - 6																				

Aリーグ女子 上位リーグ結果

	camellia	IBC	スカイ	江別第二	勝	負	順位	
camellia	/	95 <div style="display: flex; flex-direction: column; align-items: center;"> <div style="border: 1px solid black; padding: 2px;">28 - 10</div> <div style="border: 1px solid black; padding: 2px;">32 - 11</div> <div style="border: 1px solid black; padding: 2px;">23 - 13</div> <div style="border: 1px solid black; padding: 2px;">12 - 11</div> </div>	83 <div style="display: flex; flex-direction: column; align-items: center;"> <div style="border: 1px solid black; padding: 2px;">18 - 2</div> <div style="border: 1px solid black; padding: 2px;">18 - 12</div> <div style="border: 1px solid black; padding: 2px;">24 - 7</div> <div style="border: 1px solid black; padding: 2px;">23 - 3</div> </div>	79 <div style="display: flex; flex-direction: column; align-items: center;"> <div style="border: 1px solid black; padding: 2px;">23 - 15</div> <div style="border: 1px solid black; padding: 2px;">21 - 9</div> <div style="border: 1px solid black; padding: 2px;">19 - 14</div> <div style="border: 1px solid black; padding: 2px;">16 - 9</div> </div>	3		1	
IBC	45 <div style="display: flex; flex-direction: column; align-items: center;"> <div style="border: 1px solid black; padding: 2px;">10 - 28</div> <div style="border: 1px solid black; padding: 2px;">11 - 32</div> <div style="border: 1px solid black; padding: 2px;">13 - 23</div> <div style="border: 1px solid black; padding: 2px;">11 - 12</div> </div>	/	64 <div style="display: flex; flex-direction: column; align-items: center;"> <div style="border: 1px solid black; padding: 2px;">19 - 10</div> <div style="border: 1px solid black; padding: 2px;">19 - 3</div> <div style="border: 1px solid black; padding: 2px;">9 - 11</div> <div style="border: 1px solid black; padding: 2px;">17 - 6</div> </div>	59 <div style="display: flex; flex-direction: column; align-items: center;"> <div style="border: 1px solid black; padding: 2px;">12 - 14</div> <div style="border: 1px solid black; padding: 2px;">10 - 17</div> <div style="border: 1px solid black; padding: 2px;">17 - 19</div> <div style="border: 1px solid black; padding: 2px;">20 - 7</div> </div>	2	1	2	
スカイ	24 <div style="display: flex; flex-direction: column; align-items: center;"> <div style="border: 1px solid black; padding: 2px;">2 - 18</div> <div style="border: 1px solid black; padding: 2px;">12 - 18</div> <div style="border: 1px solid black; padding: 2px;">7 - 24</div> <div style="border: 1px solid black; padding: 2px;">3 - 23</div> </div>	30 <div style="display: flex; flex-direction: column; align-items: center;"> <div style="border: 1px solid black; padding: 2px;">10 - 19</div> <div style="border: 1px solid black; padding: 2px;">3 - 19</div> <div style="border: 1px solid black; padding: 2px;">11 - 9</div> <div style="border: 1px solid black; padding: 2px;">6 - 17</div> </div>	/	27 <div style="display: flex; flex-direction: column; align-items: center;"> <div style="border: 1px solid black; padding: 2px;">3 - 16</div> <div style="border: 1px solid black; padding: 2px;">10 - 15</div> <div style="border: 1px solid black; padding: 2px;">6 - 23</div> <div style="border: 1px solid black; padding: 2px;">8 - 20</div> </div>			3	4
江別第二	47 <div style="display: flex; flex-direction: column; align-items: center;"> <div style="border: 1px solid black; padding: 2px;">15 - 23</div> <div style="border: 1px solid black; padding: 2px;">9 - 21</div> <div style="border: 1px solid black; padding: 2px;">14 - 19</div> <div style="border: 1px solid black; padding: 2px;">9 - 16</div> </div>	57 <div style="display: flex; flex-direction: column; align-items: center;"> <div style="border: 1px solid black; padding: 2px;">14 - 12</div> <div style="border: 1px solid black; padding: 2px;">17 - 10</div> <div style="border: 1px solid black; padding: 2px;">19 - 17</div> <div style="border: 1px solid black; padding: 2px;">7 - 20</div> </div>	74 <div style="display: flex; flex-direction: column; align-items: center;"> <div style="border: 1px solid black; padding: 2px;">16 - 3</div> <div style="border: 1px solid black; padding: 2px;">15 - 10</div> <div style="border: 1px solid black; padding: 2px;">23 - 6</div> <div style="border: 1px solid black; padding: 2px;">20 - 8</div> </div>	/	1	2	3	

Aリーグ女子 下位リーグ結果

	向陽台	大曲	大麻	恵み野	勝	負	順位	
向陽台	/	38 <div style="display: flex; flex-direction: column; align-items: center;"> <div style="border: 1px solid black; padding: 2px;">8 - 15</div> <div style="border: 1px solid black; padding: 2px;">11 - 11</div> <div style="border: 1px solid black; padding: 2px;">9 - 10</div> <div style="border: 1px solid black; padding: 2px;">10 - 10</div> </div>	31 <div style="display: flex; flex-direction: column; align-items: center;"> <div style="border: 1px solid black; padding: 2px;">11 - 14</div> <div style="border: 1px solid black; padding: 2px;">7 - 13</div> <div style="border: 1px solid black; padding: 2px;">0 - 18</div> <div style="border: 1px solid black; padding: 2px;">13 - 18</div> </div>	26 <div style="display: flex; flex-direction: column; align-items: center;"> <div style="border: 1px solid black; padding: 2px;">5 - 30</div> <div style="border: 1px solid black; padding: 2px;">8 - 25</div> <div style="border: 1px solid black; padding: 2px;">6 - 21</div> <div style="border: 1px solid black; padding: 2px;">7 - 10</div> </div>			3	4
大曲	46 <div style="display: flex; flex-direction: column; align-items: center;"> <div style="border: 1px solid black; padding: 2px;">15 - 8</div> <div style="border: 1px solid black; padding: 2px;">11 - 11</div> <div style="border: 1px solid black; padding: 2px;">10 - 9</div> <div style="border: 1px solid black; padding: 2px;">10 - 10</div> </div>	/	40 <div style="display: flex; flex-direction: column; align-items: center;"> <div style="border: 1px solid black; padding: 2px;">13 - 12</div> <div style="border: 1px solid black; padding: 2px;">3 - 8</div> <div style="border: 1px solid black; padding: 2px;">13 - 10</div> <div style="border: 1px solid black; padding: 2px;">11 - 19</div> </div>	25 <div style="display: flex; flex-direction: column; align-items: center;"> <div style="border: 1px solid black; padding: 2px;">7 - 20</div> <div style="border: 1px solid black; padding: 2px;">6 - 27</div> <div style="border: 1px solid black; padding: 2px;">2 - 28</div> <div style="border: 1px solid black; padding: 2px;">10 - 12</div> </div>	1	2	3	
大麻	63 <div style="display: flex; flex-direction: column; align-items: center;"> <div style="border: 1px solid black; padding: 2px;">14 - 11</div> <div style="border: 1px solid black; padding: 2px;">13 - 7</div> <div style="border: 1px solid black; padding: 2px;">18 - 0</div> <div style="border: 1px solid black; padding: 2px;">18 - 13</div> </div>	49 <div style="display: flex; flex-direction: column; align-items: center;"> <div style="border: 1px solid black; padding: 2px;">12 - 13</div> <div style="border: 1px solid black; padding: 2px;">8 - 3</div> <div style="border: 1px solid black; padding: 2px;">10 - 13</div> <div style="border: 1px solid black; padding: 2px;">19 - 11</div> </div>	/	31 <div style="display: flex; flex-direction: column; align-items: center;"> <div style="border: 1px solid black; padding: 2px;">5 - 39</div> <div style="border: 1px solid black; padding: 2px;">15 - 10</div> <div style="border: 1px solid black; padding: 2px;">4 - 22</div> <div style="border: 1px solid black; padding: 2px;">7 - 15</div> </div>	2	1	2	
恵み野	86 <div style="display: flex; flex-direction: column; align-items: center;"> <div style="border: 1px solid black; padding: 2px;">30 - 5</div> <div style="border: 1px solid black; padding: 2px;">25 - 8</div> <div style="border: 1px solid black; padding: 2px;">21 - 6</div> <div style="border: 1px solid black; padding: 2px;">10 - 7</div> </div>	87 <div style="display: flex; flex-direction: column; align-items: center;"> <div style="border: 1px solid black; padding: 2px;">20 - 7</div> <div style="border: 1px solid black; padding: 2px;">27 - 6</div> <div style="border: 1px solid black; padding: 2px;">28 - 2</div> <div style="border: 1px solid black; padding: 2px;">12 - 10</div> </div>	86 <div style="display: flex; flex-direction: column; align-items: center;"> <div style="border: 1px solid black; padding: 2px;">39 - 5</div> <div style="border: 1px solid black; padding: 2px;">10 - 15</div> <div style="border: 1px solid black; padding: 2px;">22 - 4</div> <div style="border: 1px solid black; padding: 2px;">15 - 7</div> </div>	/	3		1	

男子B1

	恵明	大麻	大麻東	千歳	勝	負	順位																
恵明	45	<table border="1" style="margin: auto; border-collapse: collapse;"> <tr><td>18 - 23</td></tr> <tr><td>9 - 33</td></tr> <tr><td>3 - 26</td></tr> <tr><td>15 - 7</td></tr> </table>	18 - 23	9 - 33	3 - 26	15 - 7	89	<table border="1" style="margin: auto; border-collapse: collapse;"> <tr><td>7 - 24</td></tr> <tr><td>4 - 27</td></tr> <tr><td>12 - 19</td></tr> <tr><td>22 - 6</td></tr> </table>	7 - 24	4 - 27	12 - 19	22 - 6	76	<table border="1" style="margin: auto; border-collapse: collapse;"> <tr><td>12 - 15</td></tr> <tr><td>14 - 7</td></tr> <tr><td>19 - 8</td></tr> <tr><td>15 - 14</td></tr> </table>	12 - 15	14 - 7	19 - 8	15 - 14	60	44	1	2	3
18 - 23																							
9 - 33																							
3 - 26																							
15 - 7																							
7 - 24																							
4 - 27																							
12 - 19																							
22 - 6																							
12 - 15																							
14 - 7																							
19 - 8																							
15 - 14																							
大麻	<table border="1" style="margin: auto; border-collapse: collapse;"> <tr><td>23 - 18</td></tr> <tr><td>33 - 9</td></tr> <tr><td>26 - 3</td></tr> <tr><td>7 - 15</td></tr> </table>	23 - 18	33 - 9	26 - 3	7 - 15	45	<table border="1" style="margin: auto; border-collapse: collapse;"> <tr><td>10 - 19</td></tr> <tr><td>11 - 22</td></tr> <tr><td>18 - 20</td></tr> <tr><td>15 - 15</td></tr> </table>	10 - 19	11 - 22	18 - 20	15 - 15	54	76	<table border="1" style="margin: auto; border-collapse: collapse;"> <tr><td>13 - 10</td></tr> <tr><td>19 - 12</td></tr> <tr><td>16 - 13</td></tr> <tr><td>20 - 11</td></tr> </table>	13 - 10	19 - 12	16 - 13	20 - 11	68	46	2	1	2
23 - 18																							
33 - 9																							
26 - 3																							
7 - 15																							
10 - 19																							
11 - 22																							
18 - 20																							
15 - 15																							
13 - 10																							
19 - 12																							
16 - 13																							
20 - 11																							
大麻東	<table border="1" style="margin: auto; border-collapse: collapse;"> <tr><td>24 - 7</td></tr> <tr><td>27 - 4</td></tr> <tr><td>19 - 12</td></tr> <tr><td>6 - 22</td></tr> </table>	24 - 7	27 - 4	19 - 12	6 - 22	76	<table border="1" style="margin: auto; border-collapse: collapse;"> <tr><td>19 - 10</td></tr> <tr><td>22 - 11</td></tr> <tr><td>20 - 18</td></tr> <tr><td>15 - 15</td></tr> </table>	19 - 10	22 - 11	20 - 18	15 - 15	76	54	<table border="1" style="margin: auto; border-collapse: collapse;"> <tr><td>19 - 17</td></tr> <tr><td>29 - 8</td></tr> <tr><td>14 - 13</td></tr> <tr><td>18 - 17</td></tr> </table>	19 - 17	29 - 8	14 - 13	18 - 17	80	55	3		1
24 - 7																							
27 - 4																							
19 - 12																							
6 - 22																							
19 - 10																							
22 - 11																							
20 - 18																							
15 - 15																							
19 - 17																							
29 - 8																							
14 - 13																							
18 - 17																							
千歳	<table border="1" style="margin: auto; border-collapse: collapse;"> <tr><td>15 - 12</td></tr> <tr><td>7 - 14</td></tr> <tr><td>8 - 19</td></tr> <tr><td>14 - 15</td></tr> </table>	15 - 12	7 - 14	8 - 19	14 - 15	44	<table border="1" style="margin: auto; border-collapse: collapse;"> <tr><td>10 - 13</td></tr> <tr><td>12 - 19</td></tr> <tr><td>13 - 16</td></tr> <tr><td>11 - 20</td></tr> </table>	10 - 13	12 - 19	13 - 16	11 - 20	46	68	<table border="1" style="margin: auto; border-collapse: collapse;"> <tr><td>17 - 19</td></tr> <tr><td>8 - 29</td></tr> <tr><td>13 - 14</td></tr> <tr><td>17 - 18</td></tr> </table>	17 - 19	8 - 29	13 - 14	17 - 18	55	80		3	4
15 - 12																							
7 - 14																							
8 - 19																							
14 - 15																							
10 - 13																							
12 - 19																							
13 - 16																							
11 - 20																							
17 - 19																							
8 - 29																							
13 - 14																							
17 - 18																							

男子B2

	とうべつ学園・西当別	江陽	中央	向陽台	勝	負	順位																	
とうべつ学園・西当別	37	<table border="1" style="margin: auto; border-collapse: collapse;"> <tr><td>6 - 17</td></tr> <tr><td>11 - 10</td></tr> <tr><td>8 - 10</td></tr> <tr><td>12 - 13</td></tr> </table>	6 - 17	11 - 10	8 - 10	12 - 13	50	<table border="1" style="margin: auto; border-collapse: collapse;"> <tr><td>11 - 11</td></tr> <tr><td>2 - 16</td></tr> <tr><td>9 - 7</td></tr> <tr><td>8 - 9</td></tr> </table>	11 - 11	2 - 16	9 - 7	8 - 9	30	43	<table border="1" style="margin: auto; border-collapse: collapse;"> <tr><td>13 - 12</td></tr> <tr><td>10 - 20</td></tr> <tr><td>18 - 8</td></tr> <tr><td>8 - 6</td></tr> </table>	13 - 12	10 - 20	18 - 8	8 - 6	49	46	1	2	3
6 - 17																								
11 - 10																								
8 - 10																								
12 - 13																								
11 - 11																								
2 - 16																								
9 - 7																								
8 - 9																								
13 - 12																								
10 - 20																								
18 - 8																								
8 - 6																								
江陽	<table border="1" style="margin: auto; border-collapse: collapse;"> <tr><td>17 - 6</td></tr> <tr><td>10 - 11</td></tr> <tr><td>10 - 8</td></tr> <tr><td>13 - 12</td></tr> </table>	17 - 6	10 - 11	10 - 8	13 - 12	50	<table border="1" style="margin: auto; border-collapse: collapse;"> <tr><td>16 - 14</td></tr> <tr><td>11 - 12</td></tr> <tr><td>17 - 13</td></tr> <tr><td>11 - 10</td></tr> </table>	16 - 14	11 - 12	17 - 13	11 - 10	55	49	<table border="1" style="margin: auto; border-collapse: collapse;"> <tr><td>16 - 4</td></tr> <tr><td>15 - 26</td></tr> <tr><td>17 - 7</td></tr> <tr><td>10 - 20</td></tr> </table>	16 - 4	15 - 26	17 - 7	10 - 20	58	57	3		1	
17 - 6																								
10 - 11																								
10 - 8																								
13 - 12																								
16 - 14																								
11 - 12																								
17 - 13																								
11 - 10																								
16 - 4																								
15 - 26																								
17 - 7																								
10 - 20																								
中央	<table border="1" style="margin: auto; border-collapse: collapse;"> <tr><td>11 - 11</td></tr> <tr><td>16 - 2</td></tr> <tr><td>7 - 9</td></tr> <tr><td>9 - 8</td></tr> </table>	11 - 11	16 - 2	7 - 9	9 - 8	43	<table border="1" style="margin: auto; border-collapse: collapse;"> <tr><td>14 - 16</td></tr> <tr><td>12 - 11</td></tr> <tr><td>13 - 17</td></tr> <tr><td>10 - 11</td></tr> </table>	14 - 16	12 - 11	13 - 17	10 - 11	49	55	<table border="1" style="margin: auto; border-collapse: collapse;"> <tr><td>13 - 5</td></tr> <tr><td>16 - 11</td></tr> <tr><td>12 - 14</td></tr> <tr><td>12 - 19</td></tr> </table>	13 - 5	16 - 11	12 - 14	12 - 19	53	49	2	1	2	
11 - 11																								
16 - 2																								
7 - 9																								
9 - 8																								
14 - 16																								
12 - 11																								
13 - 17																								
10 - 11																								
13 - 5																								
16 - 11																								
12 - 14																								
12 - 19																								
向陽台	<table border="1" style="margin: auto; border-collapse: collapse;"> <tr><td>12 - 13</td></tr> <tr><td>20 - 10</td></tr> <tr><td>8 - 18</td></tr> <tr><td>6 - 8</td></tr> </table>	12 - 13	20 - 10	8 - 18	6 - 8	46	<table border="1" style="margin: auto; border-collapse: collapse;"> <tr><td>4 - 16</td></tr> <tr><td>26 - 15</td></tr> <tr><td>7 - 17</td></tr> <tr><td>20 - 10</td></tr> </table>	4 - 16	26 - 15	7 - 17	20 - 10	57	58	<table border="1" style="margin: auto; border-collapse: collapse;"> <tr><td>5 - 13</td></tr> <tr><td>11 - 16</td></tr> <tr><td>14 - 12</td></tr> <tr><td>19 - 12</td></tr> </table>	5 - 13	11 - 16	14 - 12	19 - 12	49	53		3	4	
12 - 13																								
20 - 10																								
8 - 18																								
6 - 8																								
4 - 16																								
26 - 15																								
7 - 17																								
20 - 10																								
5 - 13																								
11 - 16																								
14 - 12																								
19 - 12																								

男子B3

	広葉	青葉	樽川	勇舞	勝	負	得失点	順位												
広葉	/	56 <table border="1" style="display: inline-table; vertical-align: middle;"><tr><td>16 - 9</td></tr><tr><td>15 - 6</td></tr><tr><td>8 - 24</td></tr><tr><td>17 - 8</td></tr></table> 47	16 - 9	15 - 6	8 - 24	17 - 8	48 <table border="1" style="display: inline-table; vertical-align: middle;"><tr><td>24 - 6</td></tr><tr><td>6 - 22</td></tr><tr><td>4 - 6</td></tr><tr><td>14 - 6</td></tr></table> 40	24 - 6	6 - 22	4 - 6	14 - 6	42 <table border="1" style="display: inline-table; vertical-align: middle;"><tr><td>2 - 24</td></tr><tr><td>14 - 9</td></tr><tr><td>16 - 14</td></tr><tr><td>10 - 18</td></tr></table> 65	2 - 24	14 - 9	16 - 14	10 - 18	2	1	-15	3
16 - 9																				
15 - 6																				
8 - 24																				
17 - 8																				
24 - 6																				
6 - 22																				
4 - 6																				
14 - 6																				
2 - 24																				
14 - 9																				
16 - 14																				
10 - 18																				
青葉	47 <table border="1" style="display: inline-table; vertical-align: middle;"><tr><td>9 - 16</td></tr><tr><td>6 - 15</td></tr><tr><td>24 - 8</td></tr><tr><td>8 - 17</td></tr></table> 56	9 - 16	6 - 15	24 - 8	8 - 17	/	41 <table border="1" style="display: inline-table; vertical-align: middle;"><tr><td>23 - 3</td></tr><tr><td>6 - 8</td></tr><tr><td>0 - 18</td></tr><tr><td>12 - 18</td></tr></table> 47	23 - 3	6 - 8	0 - 18	12 - 18	42 <table border="1" style="display: inline-table; vertical-align: middle;"><tr><td>12 - 26</td></tr><tr><td>14 - 7</td></tr><tr><td>7 - 22</td></tr><tr><td>9 - 22</td></tr></table> 77	12 - 26	14 - 7	7 - 22	9 - 22		3		4
9 - 16																				
6 - 15																				
24 - 8																				
8 - 17																				
23 - 3																				
6 - 8																				
0 - 18																				
12 - 18																				
12 - 26																				
14 - 7																				
7 - 22																				
9 - 22																				
樽川	40 <table border="1" style="display: inline-table; vertical-align: middle;"><tr><td>6 - 24</td></tr><tr><td>22 - 6</td></tr><tr><td>6 - 4</td></tr><tr><td>6 - 14</td></tr></table> 48	6 - 24	22 - 6	6 - 4	6 - 14	47 <table border="1" style="display: inline-table; vertical-align: middle;"><tr><td>3 - 23</td></tr><tr><td>8 - 6</td></tr><tr><td>18 - 0</td></tr><tr><td>18 - 12</td></tr></table> 41	3 - 23	8 - 6	18 - 0	18 - 12	/	60 <table border="1" style="display: inline-table; vertical-align: middle;"><tr><td>3 - 24</td></tr><tr><td>18 - 10</td></tr><tr><td>12 - 17</td></tr><tr><td>27 - 7</td></tr></table> 58	3 - 24	18 - 10	12 - 17	27 - 7	2	1	-6	2
6 - 24																				
22 - 6																				
6 - 4																				
6 - 14																				
3 - 23																				
8 - 6																				
18 - 0																				
18 - 12																				
3 - 24																				
18 - 10																				
12 - 17																				
27 - 7																				
勇舞	65 <table border="1" style="display: inline-table; vertical-align: middle;"><tr><td>24 - 2</td></tr><tr><td>9 - 14</td></tr><tr><td>14 - 16</td></tr><tr><td>18 - 10</td></tr></table> 42	24 - 2	9 - 14	14 - 16	18 - 10	77 <table border="1" style="display: inline-table; vertical-align: middle;"><tr><td>26 - 12</td></tr><tr><td>7 - 14</td></tr><tr><td>22 - 7</td></tr><tr><td>22 - 9</td></tr></table> 42	26 - 12	7 - 14	22 - 7	22 - 9	58 <table border="1" style="display: inline-table; vertical-align: middle;"><tr><td>24 - 3</td></tr><tr><td>10 - 18</td></tr><tr><td>17 - 12</td></tr><tr><td>7 - 27</td></tr></table> 60	24 - 3	10 - 18	17 - 12	7 - 27	/	2	1	21	1
24 - 2																				
9 - 14																				
14 - 16																				
18 - 10																				
26 - 12																				
7 - 14																				
22 - 7																				
22 - 9																				
24 - 3																				
10 - 18																				
17 - 12																				
7 - 27																				

※ 3チームが勝敗数で並んだため該当チーム同士の得失点差で順位を決定

男子C1

	恵北	花川南	北斗	柏陽	勝	負	順位												
恵北	/	73 <table border="1" style="display: inline-table; vertical-align: middle;"><tr><td>19 - 13</td></tr><tr><td>13 - 12</td></tr><tr><td>22 - 17</td></tr><tr><td>19 - 12</td></tr></table> 54	19 - 13	13 - 12	22 - 17	19 - 12	127 <table border="1" style="display: inline-table; vertical-align: middle;"><tr><td>31 - 10</td></tr><tr><td>28 - 0</td></tr><tr><td>32 - 8</td></tr><tr><td>36 - 4</td></tr></table> 22	31 - 10	28 - 0	32 - 8	36 - 4	61 <table border="1" style="display: inline-table; vertical-align: middle;"><tr><td>15 - 13</td></tr><tr><td>13 - 17</td></tr><tr><td>11 - 16</td></tr><tr><td>22 - 8</td></tr></table> 54	15 - 13	13 - 17	11 - 16	22 - 8	3		1
19 - 13																			
13 - 12																			
22 - 17																			
19 - 12																			
31 - 10																			
28 - 0																			
32 - 8																			
36 - 4																			
15 - 13																			
13 - 17																			
11 - 16																			
22 - 8																			
花川南	54 <table border="1" style="display: inline-table; vertical-align: middle;"><tr><td>13 - 19</td></tr><tr><td>12 - 13</td></tr><tr><td>17 - 22</td></tr><tr><td>12 - 19</td></tr></table> 73	13 - 19	12 - 13	17 - 22	12 - 19	/	67 <table border="1" style="display: inline-table; vertical-align: middle;"><tr><td>19 - 12</td></tr><tr><td>16 - 7</td></tr><tr><td>12 - 11</td></tr><tr><td>20 - 10</td></tr></table> 40	19 - 12	16 - 7	12 - 11	20 - 10	58 <table border="1" style="display: inline-table; vertical-align: middle;"><tr><td>24 - 11</td></tr><tr><td>18 - 9</td></tr><tr><td>12 - 22</td></tr><tr><td>4 - 19</td></tr></table> 61	24 - 11	18 - 9	12 - 22	4 - 19	1	2	3
13 - 19																			
12 - 13																			
17 - 22																			
12 - 19																			
19 - 12																			
16 - 7																			
12 - 11																			
20 - 10																			
24 - 11																			
18 - 9																			
12 - 22																			
4 - 19																			
北斗	22 <table border="1" style="display: inline-table; vertical-align: middle;"><tr><td>10 - 31</td></tr><tr><td>0 - 28</td></tr><tr><td>8 - 32</td></tr><tr><td>4 - 36</td></tr></table> 127	10 - 31	0 - 28	8 - 32	4 - 36	40 <table border="1" style="display: inline-table; vertical-align: middle;"><tr><td>12 - 19</td></tr><tr><td>7 - 16</td></tr><tr><td>11 - 12</td></tr><tr><td>10 - 20</td></tr></table> 67	12 - 19	7 - 16	11 - 12	10 - 20	/	39 <table border="1" style="display: inline-table; vertical-align: middle;"><tr><td>13 - 10</td></tr><tr><td>8 - 19</td></tr><tr><td>10 - 14</td></tr><tr><td>8 - 16</td></tr></table> 59	13 - 10	8 - 19	10 - 14	8 - 16		3	4
10 - 31																			
0 - 28																			
8 - 32																			
4 - 36																			
12 - 19																			
7 - 16																			
11 - 12																			
10 - 20																			
13 - 10																			
8 - 19																			
10 - 14																			
8 - 16																			
柏陽	54 <table border="1" style="display: inline-table; vertical-align: middle;"><tr><td>13 - 15</td></tr><tr><td>17 - 13</td></tr><tr><td>16 - 11</td></tr><tr><td>8 - 22</td></tr></table> 61	13 - 15	17 - 13	16 - 11	8 - 22	61 <table border="1" style="display: inline-table; vertical-align: middle;"><tr><td>11 - 24</td></tr><tr><td>9 - 18</td></tr><tr><td>22 - 12</td></tr><tr><td>19 - 4</td></tr></table> 58	11 - 24	9 - 18	22 - 12	19 - 4	59 <table border="1" style="display: inline-table; vertical-align: middle;"><tr><td>10 - 13</td></tr><tr><td>19 - 8</td></tr><tr><td>14 - 10</td></tr><tr><td>16 - 8</td></tr></table> 39	10 - 13	19 - 8	14 - 10	16 - 8	/	2	1	2
13 - 15																			
17 - 13																			
16 - 11																			
8 - 22																			
11 - 24																			
9 - 18																			
22 - 12																			
19 - 4																			
10 - 13																			
19 - 8																			
14 - 10																			
16 - 8																			

男子C2

	東部	富丘	野幌	石狩・花川北	勝	負	順位																																				
東部	/	11 <table border="1" style="display: inline-table; vertical-align: middle;"> <tr><td>6</td><td>-</td><td>23</td></tr> <tr><td>1</td><td>-</td><td>17</td></tr> <tr><td>2</td><td>-</td><td>28</td></tr> <tr><td>2</td><td>-</td><td>23</td></tr> </table> 91	6	-	23	1	-	17	2	-	28	2	-	23	24 <table border="1" style="display: inline-table; vertical-align: middle;"> <tr><td>2</td><td>-</td><td>17</td></tr> <tr><td>4</td><td>-</td><td>11</td></tr> <tr><td>12</td><td>-</td><td>12</td></tr> <tr><td>6</td><td>-</td><td>4</td></tr> </table> 44	2	-	17	4	-	11	12	-	12	6	-	4	22 <table border="1" style="display: inline-table; vertical-align: middle;"> <tr><td>4</td><td>-</td><td>30</td></tr> <tr><td>8</td><td>-</td><td>20</td></tr> <tr><td>3</td><td>-</td><td>16</td></tr> <tr><td>7</td><td>-</td><td>20</td></tr> </table> 86	4	-	30	8	-	20	3	-	16	7	-	20	3	4	
6	-	23																																									
1	-	17																																									
2	-	28																																									
2	-	23																																									
2	-	17																																									
4	-	11																																									
12	-	12																																									
6	-	4																																									
4	-	30																																									
8	-	20																																									
3	-	16																																									
7	-	20																																									
富丘	91 <table border="1" style="display: inline-table; vertical-align: middle;"> <tr><td>23</td><td>-</td><td>6</td></tr> <tr><td>17</td><td>-</td><td>1</td></tr> <tr><td>28</td><td>-</td><td>2</td></tr> <tr><td>23</td><td>-</td><td>2</td></tr> </table> 11	23	-	6	17	-	1	28	-	2	23	-	2	/	79 <table border="1" style="display: inline-table; vertical-align: middle;"> <tr><td>22</td><td>-</td><td>6</td></tr> <tr><td>21</td><td>-</td><td>13</td></tr> <tr><td>20</td><td>-</td><td>14</td></tr> <tr><td>16</td><td>-</td><td>13</td></tr> </table> 46	22	-	6	21	-	13	20	-	14	16	-	13	41 <table border="1" style="display: inline-table; vertical-align: middle;"> <tr><td>8</td><td>-</td><td>16</td></tr> <tr><td>10</td><td>-</td><td>18</td></tr> <tr><td>13</td><td>-</td><td>8</td></tr> <tr><td>10</td><td>-</td><td>13</td></tr> </table> 55	8	-	16	10	-	18	13	-	8	10	-	13	2	1	2
23	-	6																																									
17	-	1																																									
28	-	2																																									
23	-	2																																									
22	-	6																																									
21	-	13																																									
20	-	14																																									
16	-	13																																									
8	-	16																																									
10	-	18																																									
13	-	8																																									
10	-	13																																									
野幌	44 <table border="1" style="display: inline-table; vertical-align: middle;"> <tr><td>17</td><td>-</td><td>2</td></tr> <tr><td>11</td><td>-</td><td>4</td></tr> <tr><td>12</td><td>-</td><td>12</td></tr> <tr><td>4</td><td>-</td><td>6</td></tr> </table> 24	17	-	2	11	-	4	12	-	12	4	-	6	46 <table border="1" style="display: inline-table; vertical-align: middle;"> <tr><td>6</td><td>-</td><td>22</td></tr> <tr><td>13</td><td>-</td><td>21</td></tr> <tr><td>14</td><td>-</td><td>20</td></tr> <tr><td>13</td><td>-</td><td>16</td></tr> </table> 79	6	-	22	13	-	21	14	-	20	13	-	16	/	43 <table border="1" style="display: inline-table; vertical-align: middle;"> <tr><td>5</td><td>-</td><td>20</td></tr> <tr><td>14</td><td>-</td><td>16</td></tr> <tr><td>8</td><td>-</td><td>18</td></tr> <tr><td>16</td><td>-</td><td>7</td></tr> </table> 61	5	-	20	14	-	16	8	-	18	16	-	7	1	2	3
17	-	2																																									
11	-	4																																									
12	-	12																																									
4	-	6																																									
6	-	22																																									
13	-	21																																									
14	-	20																																									
13	-	16																																									
5	-	20																																									
14	-	16																																									
8	-	18																																									
16	-	7																																									
石狩・花川北	86 <table border="1" style="display: inline-table; vertical-align: middle;"> <tr><td>30</td><td>-</td><td>4</td></tr> <tr><td>20</td><td>-</td><td>8</td></tr> <tr><td>16</td><td>-</td><td>3</td></tr> <tr><td>20</td><td>-</td><td>7</td></tr> </table> 22	30	-	4	20	-	8	16	-	3	20	-	7	55 <table border="1" style="display: inline-table; vertical-align: middle;"> <tr><td>16</td><td>-</td><td>8</td></tr> <tr><td>18</td><td>-</td><td>10</td></tr> <tr><td>8</td><td>-</td><td>13</td></tr> <tr><td>13</td><td>-</td><td>10</td></tr> </table> 41	16	-	8	18	-	10	8	-	13	13	-	10	61 <table border="1" style="display: inline-table; vertical-align: middle;"> <tr><td>20</td><td>-</td><td>5</td></tr> <tr><td>16</td><td>-</td><td>14</td></tr> <tr><td>18</td><td>-</td><td>8</td></tr> <tr><td>7</td><td>-</td><td>16</td></tr> </table> 43	20	-	5	16	-	14	18	-	8	7	-	16	/	3	1	
30	-	4																																									
20	-	8																																									
16	-	3																																									
20	-	7																																									
16	-	8																																									
18	-	10																																									
8	-	13																																									
13	-	10																																									
20	-	5																																									
16	-	14																																									
18	-	8																																									
7	-	16																																									

男子C3

	立命館	大曲	花川	江別第一	勝	負	順位																																				
立命館	/	71 <table border="1" style="display: inline-table; vertical-align: middle;"> <tr><td>21</td><td>-</td><td>10</td></tr> <tr><td>18</td><td>-</td><td>16</td></tr> <tr><td>14</td><td>-</td><td>9</td></tr> <tr><td>18</td><td>-</td><td>19</td></tr> </table> 54	21	-	10	18	-	16	14	-	9	18	-	19	42 <table border="1" style="display: inline-table; vertical-align: middle;"> <tr><td>8</td><td>-</td><td>11</td></tr> <tr><td>11</td><td>-</td><td>9</td></tr> <tr><td>16</td><td>-</td><td>6</td></tr> <tr><td>7</td><td>-</td><td>15</td></tr> </table> 41	8	-	11	11	-	9	16	-	6	7	-	15	41 <table border="1" style="display: inline-table; vertical-align: middle;"> <tr><td>8</td><td>-</td><td>12</td></tr> <tr><td>11</td><td>-</td><td>8</td></tr> <tr><td>12</td><td>-</td><td>17</td></tr> <tr><td>10</td><td>-</td><td>6</td></tr> </table> 43	8	-	12	11	-	8	12	-	17	10	-	6	2	1	1
21	-	10																																									
18	-	16																																									
14	-	9																																									
18	-	19																																									
8	-	11																																									
11	-	9																																									
16	-	6																																									
7	-	15																																									
8	-	12																																									
11	-	8																																									
12	-	17																																									
10	-	6																																									
大曲	54 <table border="1" style="display: inline-table; vertical-align: middle;"> <tr><td>10</td><td>-</td><td>21</td></tr> <tr><td>16</td><td>-</td><td>18</td></tr> <tr><td>9</td><td>-</td><td>14</td></tr> <tr><td>19</td><td>-</td><td>18</td></tr> </table> 71	10	-	21	16	-	18	9	-	14	19	-	18	/	92 <table border="1" style="display: inline-table; vertical-align: middle;"> <tr><td>21</td><td>-</td><td>12</td></tr> <tr><td>20</td><td>-</td><td>10</td></tr> <tr><td>20</td><td>-</td><td>11</td></tr> <tr><td>31</td><td>-</td><td>15</td></tr> </table> 48	21	-	12	20	-	10	20	-	11	31	-	15	62 <table border="1" style="display: inline-table; vertical-align: middle;"> <tr><td>19</td><td>-</td><td>15</td></tr> <tr><td>12</td><td>-</td><td>21</td></tr> <tr><td>15</td><td>-</td><td>2</td></tr> <tr><td>16</td><td>-</td><td>12</td></tr> </table> 50	19	-	15	12	-	21	15	-	2	16	-	12	2	1	2
10	-	21																																									
16	-	18																																									
9	-	14																																									
19	-	18																																									
21	-	12																																									
20	-	10																																									
20	-	11																																									
31	-	15																																									
19	-	15																																									
12	-	21																																									
15	-	2																																									
16	-	12																																									
花川	41 <table border="1" style="display: inline-table; vertical-align: middle;"> <tr><td>11</td><td>-</td><td>8</td></tr> <tr><td>9</td><td>-</td><td>11</td></tr> <tr><td>6</td><td>-</td><td>16</td></tr> <tr><td>15</td><td>-</td><td>7</td></tr> </table> 42	11	-	8	9	-	11	6	-	16	15	-	7	48 <table border="1" style="display: inline-table; vertical-align: middle;"> <tr><td>12</td><td>-</td><td>21</td></tr> <tr><td>10</td><td>-</td><td>20</td></tr> <tr><td>11</td><td>-</td><td>20</td></tr> <tr><td>15</td><td>-</td><td>31</td></tr> </table> 92	12	-	21	10	-	20	11	-	20	15	-	31	/	59 <table border="1" style="display: inline-table; vertical-align: middle;"> <tr><td>14</td><td>-</td><td>14</td></tr> <tr><td>17</td><td>-</td><td>8</td></tr> <tr><td>13</td><td>-</td><td>4</td></tr> <tr><td>15</td><td>-</td><td>19</td></tr> </table> 45	14	-	14	17	-	8	13	-	4	15	-	19	1	2	3
11	-	8																																									
9	-	11																																									
6	-	16																																									
15	-	7																																									
12	-	21																																									
10	-	20																																									
11	-	20																																									
15	-	31																																									
14	-	14																																									
17	-	8																																									
13	-	4																																									
15	-	19																																									
江別第一	43 <table border="1" style="display: inline-table; vertical-align: middle;"> <tr><td>12</td><td>-</td><td>8</td></tr> <tr><td>8</td><td>-</td><td>11</td></tr> <tr><td>17</td><td>-</td><td>12</td></tr> <tr><td>6</td><td>-</td><td>10</td></tr> </table> 41	12	-	8	8	-	11	17	-	12	6	-	10	50 <table border="1" style="display: inline-table; vertical-align: middle;"> <tr><td>15</td><td>-</td><td>19</td></tr> <tr><td>21</td><td>-</td><td>12</td></tr> <tr><td>2</td><td>-</td><td>15</td></tr> <tr><td>12</td><td>-</td><td>16</td></tr> </table> 62	15	-	19	21	-	12	2	-	15	12	-	16	45 <table border="1" style="display: inline-table; vertical-align: middle;"> <tr><td>14</td><td>-</td><td>14</td></tr> <tr><td>8</td><td>-</td><td>17</td></tr> <tr><td>4</td><td>-</td><td>13</td></tr> <tr><td>19</td><td>-</td><td>15</td></tr> </table> 59	14	-	14	8	-	17	4	-	13	19	-	15	/	1	2	4
12	-	8																																									
8	-	11																																									
17	-	12																																									
6	-	10																																									
15	-	19																																									
21	-	12																																									
2	-	15																																									
12	-	16																																									
14	-	14																																									
8	-	17																																									
4	-	13																																									
19	-	15																																									

※勝敗数が並んだため該当チーム同士の勝敗で順位を決定

女子B1

	青葉	千歳	恵明	中央	勝	負	順位												
青葉	76	<table border="1" style="margin: auto;"> <tr><td>15 - 10</td></tr> <tr><td>27 - 2</td></tr> <tr><td>17 - 5</td></tr> <tr><td>17 - 15</td></tr> </table>	15 - 10	27 - 2	17 - 5	17 - 15	<table border="1" style="margin: auto;"> <tr><td>10 - 12</td></tr> <tr><td>14 - 9</td></tr> <tr><td>8 - 17</td></tr> <tr><td>15 - 20</td></tr> </table>	10 - 12	14 - 9	8 - 17	15 - 20	<table border="1" style="margin: auto;"> <tr><td>12 - 14</td></tr> <tr><td>10 - 11</td></tr> <tr><td>16 - 8</td></tr> <tr><td>20 - 13</td></tr> </table>	12 - 14	10 - 11	16 - 8	20 - 13	2	1	2
15 - 10																			
27 - 2																			
17 - 5																			
17 - 15																			
10 - 12																			
14 - 9																			
8 - 17																			
15 - 20																			
12 - 14																			
10 - 11																			
16 - 8																			
20 - 13																			
千歳	<table border="1" style="margin: auto;"> <tr><td>10 - 15</td></tr> <tr><td>2 - 27</td></tr> <tr><td>5 - 17</td></tr> <tr><td>15 - 17</td></tr> </table>	10 - 15	2 - 27	5 - 17	15 - 17	76	<table border="1" style="margin: auto;"> <tr><td>10 - 25</td></tr> <tr><td>4 - 13</td></tr> <tr><td>13 - 7</td></tr> <tr><td>12 - 19</td></tr> </table>	10 - 25	4 - 13	13 - 7	12 - 19	<table border="1" style="margin: auto;"> <tr><td>12 - 8</td></tr> <tr><td>8 - 8</td></tr> <tr><td>12 - 12</td></tr> <tr><td>8 - 18</td></tr> </table>	12 - 8	8 - 8	12 - 12	8 - 18		3	4
10 - 15																			
2 - 27																			
5 - 17																			
15 - 17																			
10 - 25																			
4 - 13																			
13 - 7																			
12 - 19																			
12 - 8																			
8 - 8																			
12 - 12																			
8 - 18																			
恵明	<table border="1" style="margin: auto;"> <tr><td>12 - 10</td></tr> <tr><td>9 - 14</td></tr> <tr><td>17 - 8</td></tr> <tr><td>20 - 15</td></tr> </table>	12 - 10	9 - 14	17 - 8	20 - 15	<table border="1" style="margin: auto;"> <tr><td>25 - 10</td></tr> <tr><td>13 - 4</td></tr> <tr><td>7 - 13</td></tr> <tr><td>19 - 12</td></tr> </table>	25 - 10	13 - 4	7 - 13	19 - 12	39	<table border="1" style="margin: auto;"> <tr><td>18 - 2</td></tr> <tr><td>15 - 11</td></tr> <tr><td>19 - 7</td></tr> <tr><td>15 - 9</td></tr> </table>	18 - 2	15 - 11	19 - 7	15 - 9	3		1
12 - 10																			
9 - 14																			
17 - 8																			
20 - 15																			
25 - 10																			
13 - 4																			
7 - 13																			
19 - 12																			
18 - 2																			
15 - 11																			
19 - 7																			
15 - 9																			
中央	<table border="1" style="margin: auto;"> <tr><td>14 - 12</td></tr> <tr><td>11 - 10</td></tr> <tr><td>8 - 16</td></tr> <tr><td>13 - 20</td></tr> </table>	14 - 12	11 - 10	8 - 16	13 - 20	<table border="1" style="margin: auto;"> <tr><td>8 - 12</td></tr> <tr><td>8 - 8</td></tr> <tr><td>12 - 12</td></tr> <tr><td>18 - 8</td></tr> </table>	8 - 12	8 - 8	12 - 12	18 - 8	<table border="1" style="margin: auto;"> <tr><td>2 - 18</td></tr> <tr><td>11 - 15</td></tr> <tr><td>7 - 19</td></tr> <tr><td>9 - 15</td></tr> </table>	2 - 18	11 - 15	7 - 19	9 - 15	67	1	2	3
14 - 12																			
11 - 10																			
8 - 16																			
13 - 20																			
8 - 12																			
8 - 8																			
12 - 12																			
18 - 8																			
2 - 18																			
11 - 15																			
7 - 19																			
9 - 15																			

女子B2

	恵庭	勇舞	大麻東	恵北	勝	負	順位												
恵庭	40	<table border="1" style="margin: auto;"> <tr><td>6 - 11</td></tr> <tr><td>14 - 6</td></tr> <tr><td>5 - 13</td></tr> <tr><td>15 - 14</td></tr> </table>	6 - 11	14 - 6	5 - 13	15 - 14	<table border="1" style="margin: auto;"> <tr><td>6 - 21</td></tr> <tr><td>12 - 18</td></tr> <tr><td>13 - 13</td></tr> <tr><td>6 - 8</td></tr> </table>	6 - 21	12 - 18	13 - 13	6 - 8	<table border="1" style="margin: auto;"> <tr><td>8 - 16</td></tr> <tr><td>4 - 15</td></tr> <tr><td>5 - 13</td></tr> <tr><td>21 - 9</td></tr> </table>	8 - 16	4 - 15	5 - 13	21 - 9		3	4
6 - 11																			
14 - 6																			
5 - 13																			
15 - 14																			
6 - 21																			
12 - 18																			
13 - 13																			
6 - 8																			
8 - 16																			
4 - 15																			
5 - 13																			
21 - 9																			
勇舞	<table border="1" style="margin: auto;"> <tr><td>11 - 6</td></tr> <tr><td>6 - 14</td></tr> <tr><td>13 - 5</td></tr> <tr><td>14 - 15</td></tr> </table>	11 - 6	6 - 14	13 - 5	14 - 15	40	<table border="1" style="margin: auto;"> <tr><td>12 - 15</td></tr> <tr><td>6 - 22</td></tr> <tr><td>13 - 6</td></tr> <tr><td>11 - 16</td></tr> </table>	12 - 15	6 - 22	13 - 6	11 - 16	<table border="1" style="margin: auto;"> <tr><td>7 - 14</td></tr> <tr><td>8 - 9</td></tr> <tr><td>5 - 13</td></tr> <tr><td>7 - 9</td></tr> </table>	7 - 14	8 - 9	5 - 13	7 - 9	1	2	3
11 - 6																			
6 - 14																			
13 - 5																			
14 - 15																			
12 - 15																			
6 - 22																			
13 - 6																			
11 - 16																			
7 - 14																			
8 - 9																			
5 - 13																			
7 - 9																			
大麻東	<table border="1" style="margin: auto;"> <tr><td>21 - 6</td></tr> <tr><td>18 - 12</td></tr> <tr><td>13 - 13</td></tr> <tr><td>8 - 6</td></tr> </table>	21 - 6	18 - 12	13 - 13	8 - 6	<table border="1" style="margin: auto;"> <tr><td>15 - 12</td></tr> <tr><td>22 - 6</td></tr> <tr><td>6 - 13</td></tr> <tr><td>16 - 11</td></tr> </table>	15 - 12	22 - 6	6 - 13	16 - 11	42	<table border="1" style="margin: auto;"> <tr><td>10 - 10</td></tr> <tr><td>8 - 11</td></tr> <tr><td>18 - 8</td></tr> <tr><td>16 - 11</td></tr> </table>	10 - 10	8 - 11	18 - 8	16 - 11	3		1
21 - 6																			
18 - 12																			
13 - 13																			
8 - 6																			
15 - 12																			
22 - 6																			
6 - 13																			
16 - 11																			
10 - 10																			
8 - 11																			
18 - 8																			
16 - 11																			
恵北	<table border="1" style="margin: auto;"> <tr><td>16 - 8</td></tr> <tr><td>15 - 4</td></tr> <tr><td>13 - 5</td></tr> <tr><td>9 - 21</td></tr> </table>	16 - 8	15 - 4	13 - 5	9 - 21	<table border="1" style="margin: auto;"> <tr><td>14 - 7</td></tr> <tr><td>9 - 8</td></tr> <tr><td>13 - 5</td></tr> <tr><td>9 - 7</td></tr> </table>	14 - 7	9 - 8	13 - 5	9 - 7	<table border="1" style="margin: auto;"> <tr><td>10 - 10</td></tr> <tr><td>11 - 8</td></tr> <tr><td>8 - 18</td></tr> <tr><td>11 - 16</td></tr> </table>	10 - 10	11 - 8	8 - 18	11 - 16	52	2	1	2
16 - 8																			
15 - 4																			
13 - 5																			
9 - 21																			
14 - 7																			
9 - 8																			
13 - 5																			
9 - 7																			
10 - 10																			
11 - 8																			
8 - 18																			
11 - 16																			

女子B3

	広葉・東部	柏陽	江別第三	野幌	勝	負	順位
広葉・東部		37 <div style="display: flex; justify-content: space-between; align-items: center;"> <div style="border: 1px solid black; padding: 2px;">7 - 15</div> <div style="border: 1px solid black; padding: 2px;">2 - 13</div> <div style="border: 1px solid black; padding: 2px;">16 - 16</div> <div style="border: 1px solid black; padding: 2px;">12 - 22</div> </div>	52 <div style="display: flex; justify-content: space-between; align-items: center;"> <div style="border: 1px solid black; padding: 2px;">16 - 8</div> <div style="border: 1px solid black; padding: 2px;">14 - 6</div> <div style="border: 1px solid black; padding: 2px;">17 - 7</div> <div style="border: 1px solid black; padding: 2px;">5 - 8</div> </div>	27 <div style="display: flex; justify-content: space-between; align-items: center;"> <div style="border: 1px solid black; padding: 2px;">12 - 12</div> <div style="border: 1px solid black; padding: 2px;">4 - 12</div> <div style="border: 1px solid black; padding: 2px;">9 - 11</div> <div style="border: 1px solid black; padding: 2px;">2 - 10</div> </div>	1	2	3
柏陽	66 <div style="display: flex; justify-content: space-between; align-items: center;"> <div style="border: 1px solid black; padding: 2px;">15 - 7</div> <div style="border: 1px solid black; padding: 2px;">13 - 2</div> <div style="border: 1px solid black; padding: 2px;">16 - 16</div> <div style="border: 1px solid black; padding: 2px;">22 - 12</div> </div>		69 <div style="display: flex; justify-content: space-between; align-items: center;"> <div style="border: 1px solid black; padding: 2px;">28 - 3</div> <div style="border: 1px solid black; padding: 2px;">16 - 6</div> <div style="border: 1px solid black; padding: 2px;">15 - 10</div> <div style="border: 1px solid black; padding: 2px;">10 - 7</div> </div>	48 <div style="display: flex; justify-content: space-between; align-items: center;"> <div style="border: 1px solid black; padding: 2px;">16 - 6</div> <div style="border: 1px solid black; padding: 2px;">9 - 11</div> <div style="border: 1px solid black; padding: 2px;">8 - 4</div> <div style="border: 1px solid black; padding: 2px;">15 - 3</div> </div>	3		1
江別第三	29 <div style="display: flex; justify-content: space-between; align-items: center;"> <div style="border: 1px solid black; padding: 2px;">8 - 16</div> <div style="border: 1px solid black; padding: 2px;">6 - 14</div> <div style="border: 1px solid black; padding: 2px;">7 - 17</div> <div style="border: 1px solid black; padding: 2px;">8 - 5</div> </div>	26 <div style="display: flex; justify-content: space-between; align-items: center;"> <div style="border: 1px solid black; padding: 2px;">3 - 28</div> <div style="border: 1px solid black; padding: 2px;">6 - 16</div> <div style="border: 1px solid black; padding: 2px;">10 - 15</div> <div style="border: 1px solid black; padding: 2px;">7 - 10</div> </div>		29 <div style="display: flex; justify-content: space-between; align-items: center;"> <div style="border: 1px solid black; padding: 2px;">4 - 3</div> <div style="border: 1px solid black; padding: 2px;">7 - 15</div> <div style="border: 1px solid black; padding: 2px;">11 - 20</div> <div style="border: 1px solid black; padding: 2px;">7 - 6</div> </div>		3	4
野幌	45 <div style="display: flex; justify-content: space-between; align-items: center;"> <div style="border: 1px solid black; padding: 2px;">12 - 12</div> <div style="border: 1px solid black; padding: 2px;">12 - 4</div> <div style="border: 1px solid black; padding: 2px;">11 - 9</div> <div style="border: 1px solid black; padding: 2px;">10 - 2</div> </div>	24 <div style="display: flex; justify-content: space-between; align-items: center;"> <div style="border: 1px solid black; padding: 2px;">6 - 16</div> <div style="border: 1px solid black; padding: 2px;">11 - 9</div> <div style="border: 1px solid black; padding: 2px;">4 - 8</div> <div style="border: 1px solid black; padding: 2px;">3 - 15</div> </div>	44 <div style="display: flex; justify-content: space-between; align-items: center;"> <div style="border: 1px solid black; padding: 2px;">3 - 4</div> <div style="border: 1px solid black; padding: 2px;">15 - 7</div> <div style="border: 1px solid black; padding: 2px;">20 - 11</div> <div style="border: 1px solid black; padding: 2px;">6 - 7</div> </div>		2	1	2

女子C1

	江別第一	花川・花川北	富丘	樽川	勝	負	順位
江別第一		52 <div style="display: flex; justify-content: space-between; align-items: center;"> <div style="border: 1px solid black; padding: 2px;">10 - 6</div> <div style="border: 1px solid black; padding: 2px;">8 - 8</div> <div style="border: 1px solid black; padding: 2px;">12 - 0</div> <div style="border: 1px solid black; padding: 2px;">22 - 3</div> </div>	45 <div style="display: flex; justify-content: space-between; align-items: center;"> <div style="border: 1px solid black; padding: 2px;">3 - 14</div> <div style="border: 1px solid black; padding: 2px;">18 - 3</div> <div style="border: 1px solid black; padding: 2px;">16 - 4</div> <div style="border: 1px solid black; padding: 2px;">8 - 6</div> </div>	42 <div style="display: flex; justify-content: space-between; align-items: center;"> <div style="border: 1px solid black; padding: 2px;">9 - 8</div> <div style="border: 1px solid black; padding: 2px;">11 - 10</div> <div style="border: 1px solid black; padding: 2px;">10 - 10</div> <div style="border: 1px solid black; padding: 2px;">12 - 12</div> </div>	3		1
花川・花川北	17 <div style="display: flex; justify-content: space-between; align-items: center;"> <div style="border: 1px solid black; padding: 2px;">6 - 10</div> <div style="border: 1px solid black; padding: 2px;">8 - 8</div> <div style="border: 1px solid black; padding: 2px;">0 - 12</div> <div style="border: 1px solid black; padding: 2px;">3 - 22</div> </div>		24 <div style="display: flex; justify-content: space-between; align-items: center;"> <div style="border: 1px solid black; padding: 2px;">0 - 10</div> <div style="border: 1px solid black; padding: 2px;">7 - 14</div> <div style="border: 1px solid black; padding: 2px;">11 - 21</div> <div style="border: 1px solid black; padding: 2px;">6 - 14</div> </div>	27 <div style="display: flex; justify-content: space-between; align-items: center;"> <div style="border: 1px solid black; padding: 2px;">2 - 10</div> <div style="border: 1px solid black; padding: 2px;">12 - 8</div> <div style="border: 1px solid black; padding: 2px;">7 - 11</div> <div style="border: 1px solid black; padding: 2px;">6 - 9</div> </div>		3	4
富丘	27 <div style="display: flex; justify-content: space-between; align-items: center;"> <div style="border: 1px solid black; padding: 2px;">14 - 3</div> <div style="border: 1px solid black; padding: 2px;">3 - 18</div> <div style="border: 1px solid black; padding: 2px;">4 - 16</div> <div style="border: 1px solid black; padding: 2px;">6 - 8</div> </div>	59 <div style="display: flex; justify-content: space-between; align-items: center;"> <div style="border: 1px solid black; padding: 2px;">10 - 0</div> <div style="border: 1px solid black; padding: 2px;">14 - 7</div> <div style="border: 1px solid black; padding: 2px;">21 - 11</div> <div style="border: 1px solid black; padding: 2px;">14 - 6</div> </div>		29 <div style="display: flex; justify-content: space-between; align-items: center;"> <div style="border: 1px solid black; padding: 2px;">3 - 6</div> <div style="border: 1px solid black; padding: 2px;">9 - 10</div> <div style="border: 1px solid black; padding: 2px;">9 - 6</div> <div style="border: 1px solid black; padding: 2px;">8 - 4</div> </div>	2	1	2
樽川	40 <div style="display: flex; justify-content: space-between; align-items: center;"> <div style="border: 1px solid black; padding: 2px;">8 - 9</div> <div style="border: 1px solid black; padding: 2px;">10 - 11</div> <div style="border: 1px solid black; padding: 2px;">10 - 10</div> <div style="border: 1px solid black; padding: 2px;">12 - 12</div> </div>	38 <div style="display: flex; justify-content: space-between; align-items: center;"> <div style="border: 1px solid black; padding: 2px;">10 - 2</div> <div style="border: 1px solid black; padding: 2px;">8 - 12</div> <div style="border: 1px solid black; padding: 2px;">11 - 7</div> <div style="border: 1px solid black; padding: 2px;">9 - 6</div> </div>	26 <div style="display: flex; justify-content: space-between; align-items: center;"> <div style="border: 1px solid black; padding: 2px;">6 - 3</div> <div style="border: 1px solid black; padding: 2px;">10 - 9</div> <div style="border: 1px solid black; padding: 2px;">6 - 9</div> <div style="border: 1px solid black; padding: 2px;">4 - 8</div> </div>		1	2	3

女子C2

	とうべつ学園・西当別	江陽	西の里	立命館	緑葉	勝	負
とうべつ学園・西当別		24 $\begin{matrix} \boxed{6 - 16} \\ \boxed{6 - 11} \\ \boxed{4 - 14} \\ \boxed{8 - 16} \end{matrix}$ 57	43 $\begin{matrix} \boxed{2 - 13} \\ \boxed{8 - 15} \\ \boxed{11 - 16} \\ \boxed{22 - 6} \end{matrix}$ 50	$\begin{matrix} \boxed{-} \\ \boxed{-} \\ \boxed{-} \\ \boxed{-} \end{matrix}$	36 $\begin{matrix} \boxed{7 - 13} \\ \boxed{6 - 20} \\ \boxed{8 - 10} \\ \boxed{15 - 8} \end{matrix}$ 51		3
江陽	57 $\begin{matrix} \boxed{16 - 6} \\ \boxed{11 - 6} \\ \boxed{14 - 4} \\ \boxed{16 - 8} \end{matrix}$ 24		$\begin{matrix} \boxed{-} \\ \boxed{-} \\ \boxed{-} \\ \boxed{-} \end{matrix}$	29 $\begin{matrix} \boxed{10 - 12} \\ \boxed{2 - 9} \\ \boxed{11 - 10} \\ \boxed{6 - 15} \end{matrix}$ 46	44 $\begin{matrix} \boxed{19 - 11} \\ \boxed{11 - 7} \\ \boxed{8 - 9} \\ \boxed{6 - 6} \end{matrix}$ 33	2	1
西の里	50 $\begin{matrix} \boxed{13 - 2} \\ \boxed{15 - 8} \\ \boxed{16 - 11} \\ \boxed{6 - 22} \end{matrix}$ 43			32 $\begin{matrix} \boxed{6 - 13} \\ \boxed{8 - 3} \\ \boxed{12 - 16} \\ \boxed{6 - 9} \end{matrix}$ 41	45 $\begin{matrix} \boxed{17 - 8} \\ \boxed{9 - 10} \\ \boxed{13 - 16} \\ \boxed{6 - 13} \end{matrix}$ 47	1	2
立命館	$\begin{matrix} \boxed{-} \\ \boxed{-} \\ \boxed{-} \\ \boxed{-} \end{matrix}$	46 $\begin{matrix} \boxed{12 - 10} \\ \boxed{9 - 2} \\ \boxed{10 - 11} \\ \boxed{15 - 6} \end{matrix}$ 29	41 $\begin{matrix} \boxed{13 - 6} \\ \boxed{3 - 8} \\ \boxed{16 - 12} \\ \boxed{9 - 6} \end{matrix}$ 32		28 $\begin{matrix} \boxed{12 - 1} \\ \boxed{3 - 10} \\ \boxed{8 - 4} \\ \boxed{5 - 9} \end{matrix}$ 24	3	
緑葉	51 $\begin{matrix} \boxed{13 - 7} \\ \boxed{20 - 6} \\ \boxed{10 - 8} \\ \boxed{8 - 15} \end{matrix}$ 36	33 $\begin{matrix} \boxed{11 - 19} \\ \boxed{7 - 11} \\ \boxed{9 - 8} \\ \boxed{6 - 6} \end{matrix}$ 44	47 $\begin{matrix} \boxed{8 - 17} \\ \boxed{10 - 9} \\ \boxed{16 - 13} \\ \boxed{13 - 6} \end{matrix}$ 45	24 $\begin{matrix} \boxed{1 - 12} \\ \boxed{10 - 3} \\ \boxed{4 - 8} \\ \boxed{9 - 5} \end{matrix}$ 28		2	2

※変則リーグにより試合数が各チーム異なるため順位はなし